

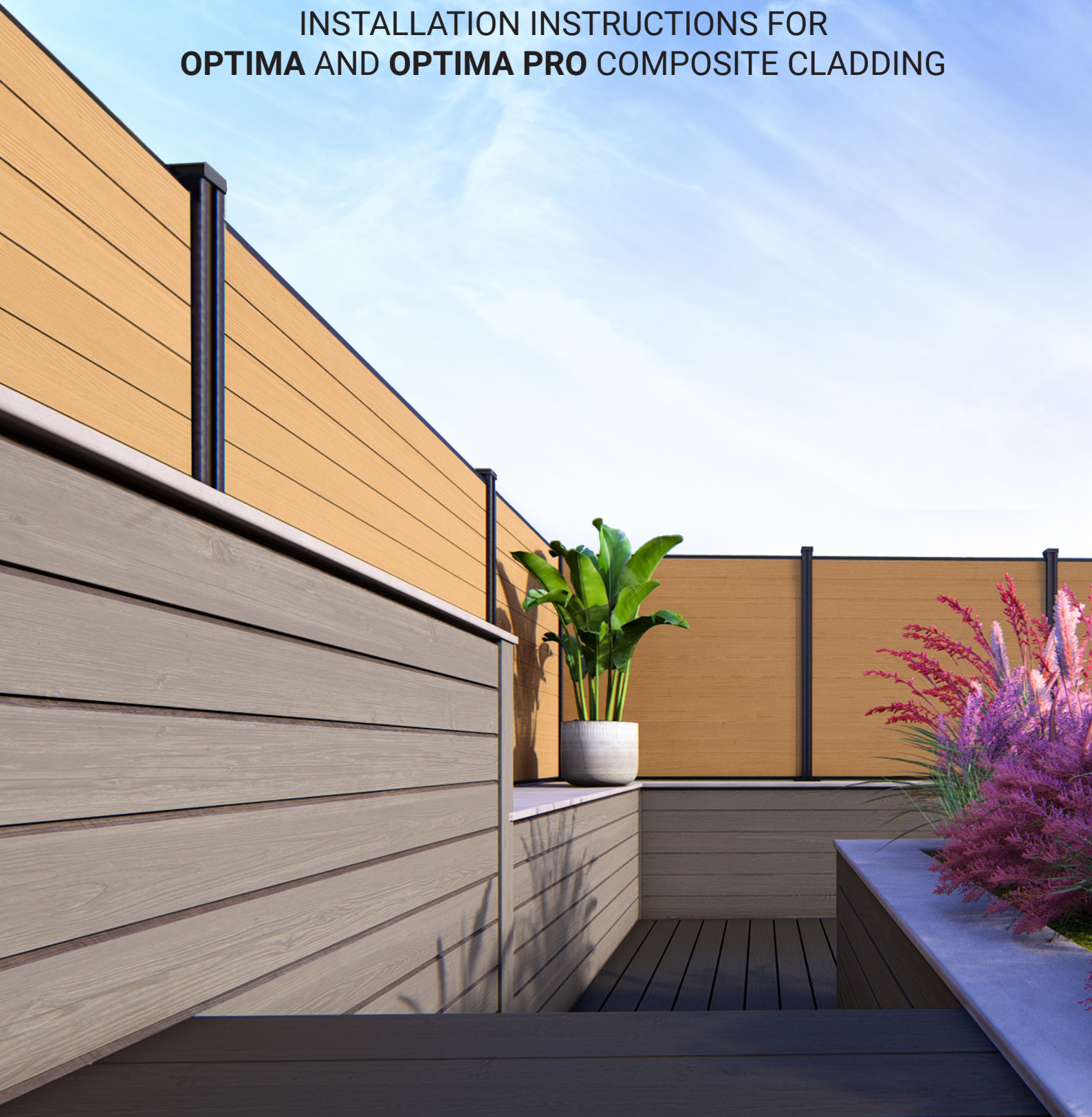

COMPOSITE CLADDING

INSTALLATION INSTRUCTIONS FOR
OPTIMA AND OPTIMA PRO COMPOSITE CLADDING



The Optima Cladding Range

OPTIMA

Uncapped with a brushed finish and monotone colour

10
YEAR
WARRANTY



Cedar

Grey

Black

Walnut

OPTIMA PRO

Capped with a woodgrain finish and duotone colour

25
YEAR
WARRANTY

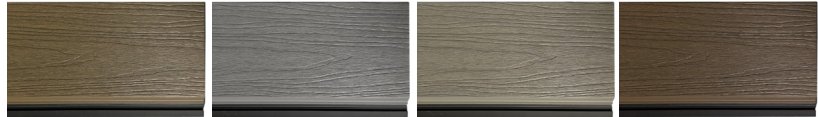

Teak

Grey

Driftwood

Walnut

Installation

Before you start the installation, please make sure you have all related accessories listed below.

A clean, flat and strong surface is needed to install wall cladding products correctly.

It is recommended that the cladding is stored on a flat surface and allowed to acclimatise for 24 hours before installation.



Optima (156mm x 21mm)
or
Optima Pro (174mm x 21mm)
wall cladding

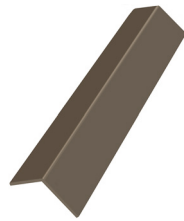

Optima L Trim
50mm x 50mm
(uncapped)

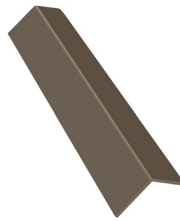

Optima Pro L Trim
50mm x 50mm
(capped)



Composite battens
Use suitable fasteners to
fix the composite batten
back to the structure
(not supplied)



Starter clips
for installation
of wall cladding -
supplied painted
black
(screws supplied)

Composite products SHOULD NOT be installed directly onto a flat surface. They must be installed onto a substructure (composite or timber battens) to provide adequate air flow behind the cladding. The substructure (minimum 25mm deep) should be created behind the cladding surface for adequate ventilation.

CladPlus is installed using standard tools and safety equipment:



1.

Give some consideration to the layout of the cladding boards to the area you wish to clad.
Fix the composite battens vertically with centres of 300-400mm between battens.

Use suitable fasteners to fix composite battens back to the sub structure. We recommend pilot drilling the composite battens prior to fixing them to the sub structure. Fasteners should be fixed at 500mm intervals along this length.

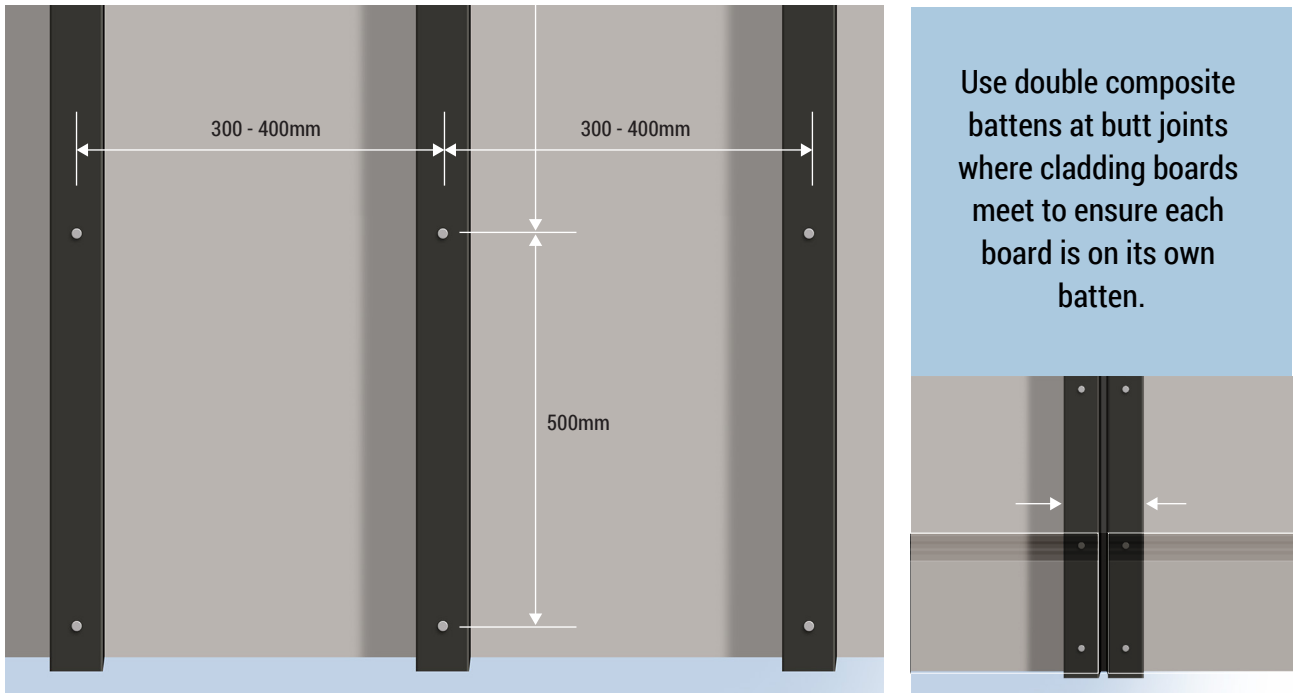

2.

Using the screws provided, fix starter clips to the bottom of each composite batten, allowing a gap of 10mm from the base of the clip to the ground.

It is important to make sure that all the starter clips on every composite batten are level. This will ensure that the bottom cladding board will be level horizontally.

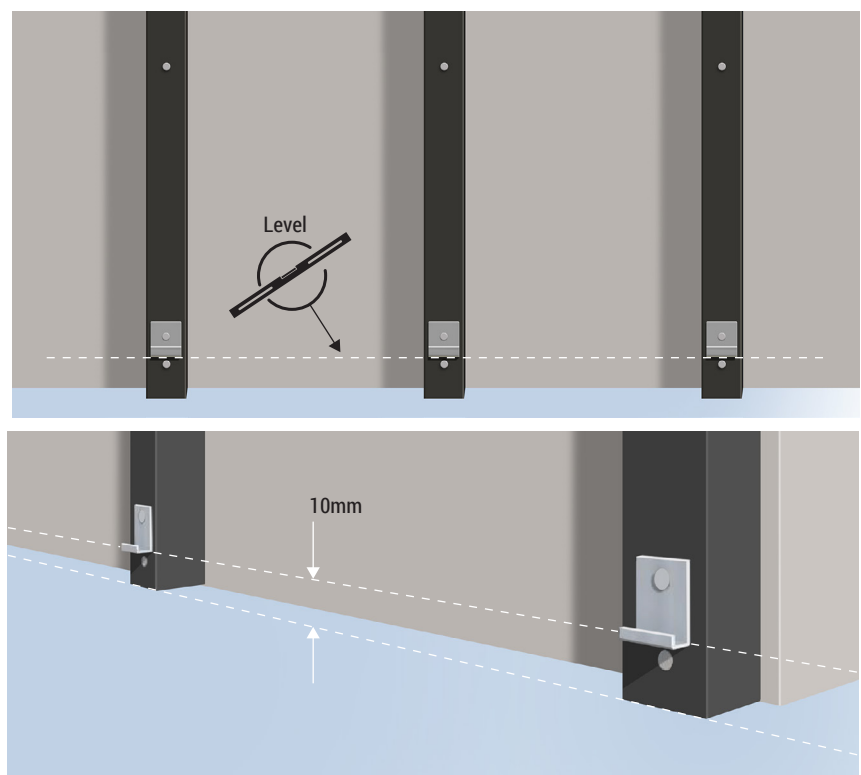

3.

Place the first cladding board onto the starter clips and fix the cladding board to the composite battens with screws (not supplied) located in the tongue of the board - see image below.

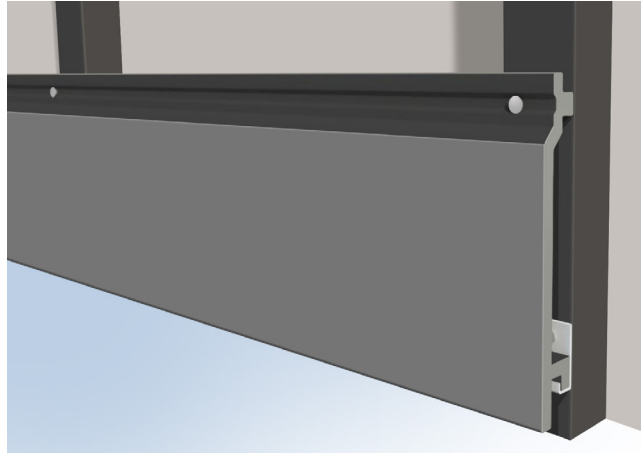
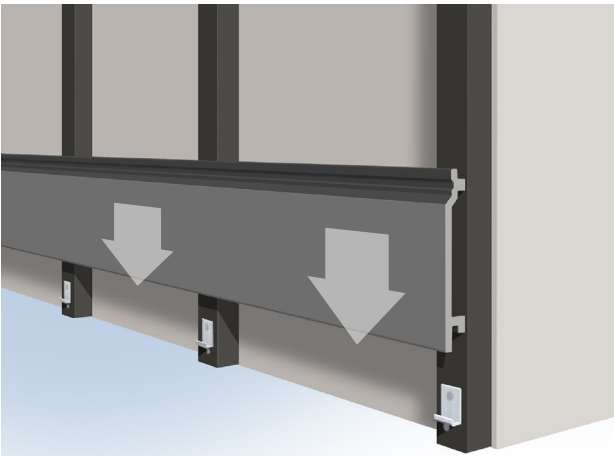

4.

Continue installing cladding boards one by one until you reach the top of the substructure. Please make sure each row is firmly locked on to the row of boards below.

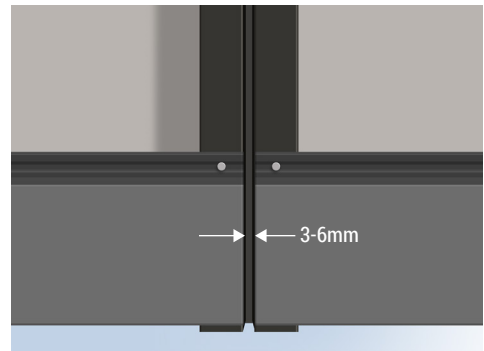
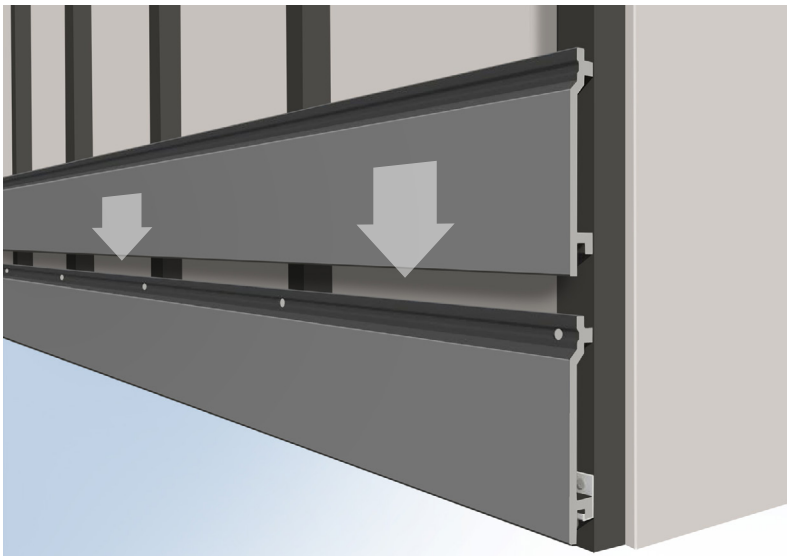

Leave a gap of 3-6mm between two abutting boards to allow for expansion, contraction, and ventilation (see temperature guide chart on last page).

Boards can be installed with a continuous vertical butt joint that runs to the entire height of the cladded area. Alternatively, you may opt for a staggered butt joint that affords extra strength and stability to the cladded area (see below).

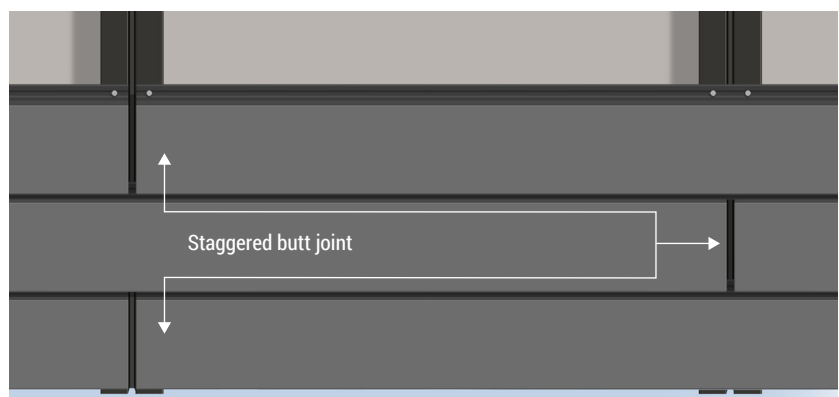
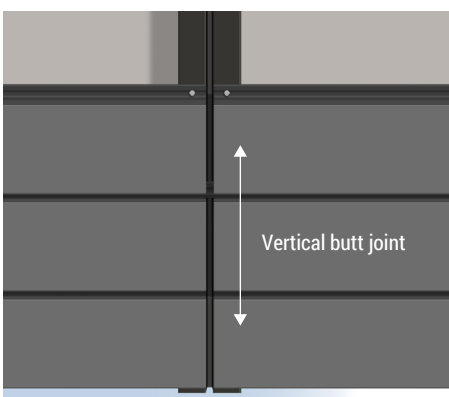

5.

At the top of the area to be cladded, if you are unable to fix a full cladding board width in place, you will need to cut down the cladding board along its length.

Fix 14mm thick 'packers' (not supplied) to the top of each composite batten, positioned as shown below.

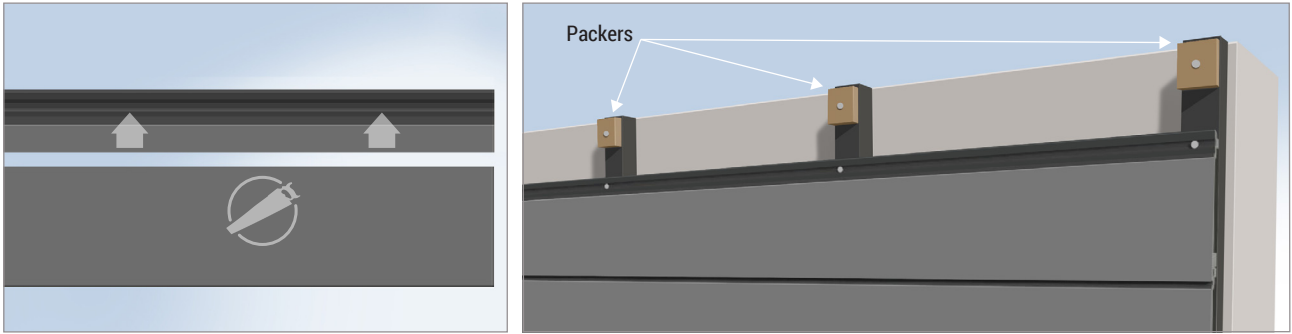

6.

Fix the board that you have cut down into place with colour matched screws into the packers.

We recommend fitting our L trim along the top of the cladding. Use our colour matched screws for best results.

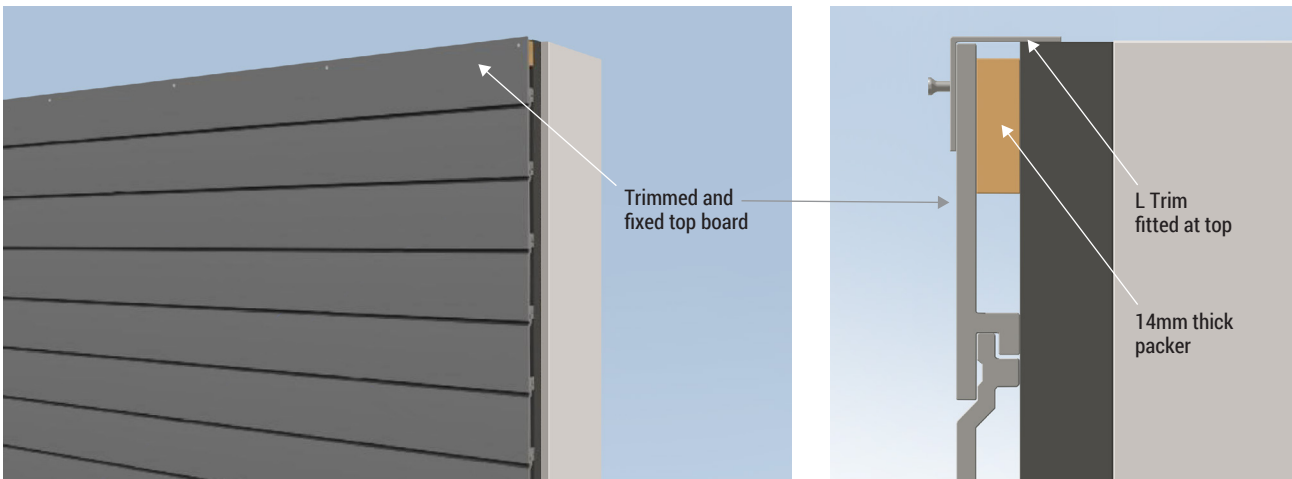

7.

At corners, use the L-trim fixed with colour matched screws at 30cm centres.

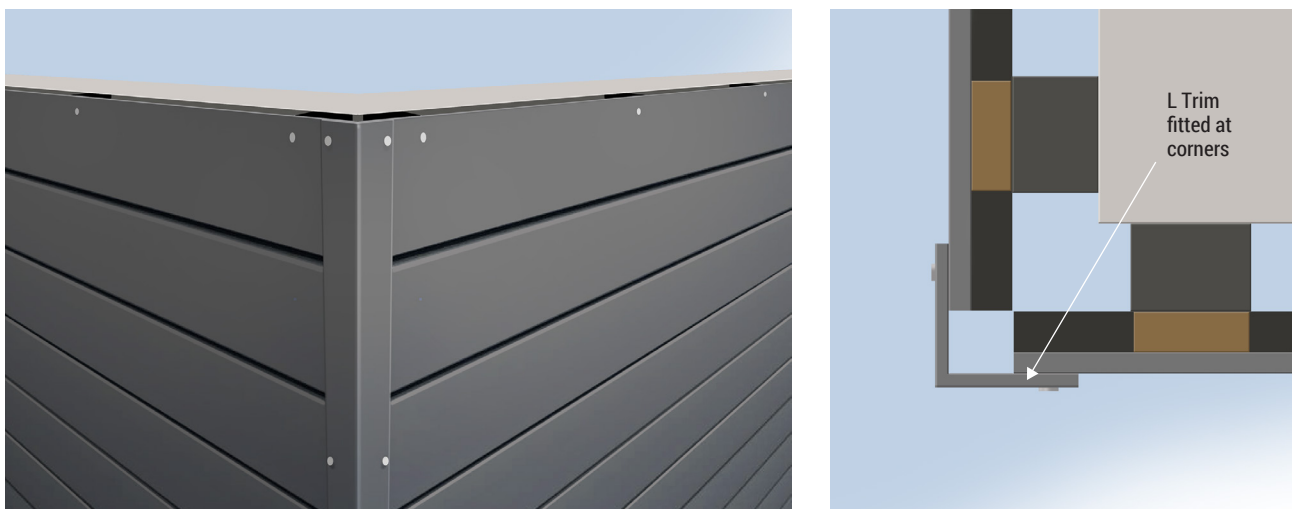

Important

Composite cladding naturally expands and contracts in various temperatures, we recommend that, during installation, suitable gaps are maintained at butt joints as outlined in the information opposite.

TEMPERATURE GUIDE (DURING INSTALLATION)

Outside temperature	End to end gap
Below 4°C	6mm
Between 4°C and 25°C	3mm
26°C and above	1mm

Maintenance and Care

Compared to other natural timber materials, our composite cladding is a low-maintenance material that comes with the reassurance of continual performance year-on-year. However, we know that with a little care, our boards can continue to look their sparkling best.

We recommend a routine clean of your cladding every 6 months to clear away dirt that can accumulate and sit on your boards over the course of time. We advise that proper safety precautions are taken when accessing the cladding.

For general cleaning - we recommend applying warm soapy water to the surface of the cladding boards and cleaning with a soft bristled brush or sponge.

For a deeper clean - you can opt for using a jet wash with no greater than 1900 PSI to clear surface debris from your cladded area.

Regardless of which cleaning option you choose, be sure to clean along the length of the boards to avoid the accumulation of material that can interfere with drainage.



South Wales Showroom

Unit B, Dragon Parc B, Abercanaid, CF48 1YL T: 0800 028 8756

www.greensquares.co.uk

Sales Offices

Berkshire Office: E: info@greensquares.co.uk T: 01727 634 975

Hertfordshire Office: E: info@greensquares.co.uk T: 01727 614 391

CladPlus is a division of Greensquares Products Limited

